

FURALED

Compact and optimised LED illuminator

Fura-2 or Fura-8 Calcium Imaging

DATASHEET

We introduced LED based Fura-2 systems a number of years ago, but only with 360nm isosbestic ratioing (due to limitations in LED availability). We are delighted to now offer full 340nm / 380nm ratiometric Fura-2 imaging with integrated excitation filters. Similarly, the LED configuration for Fura-8 is also available.

Ratiometric calcium imaging with LEDs can work very well, but, due to the relatively narrow bandwidths and spectral variations of individual LEDs, it does require attention to detail. The FuraLED works directly with our OptoLED controller and makes the process simple, as we take care of the LED selection and intensity regulation to make your experiments work.

We understand that most researchers will also want to use visible indicators and, quite likely, their existing light source alongside the FuraLED. To simplify this the coupling is equipped with a straight-through port to accommodate any fibre based illuminator, or additional Cairn LEDs.

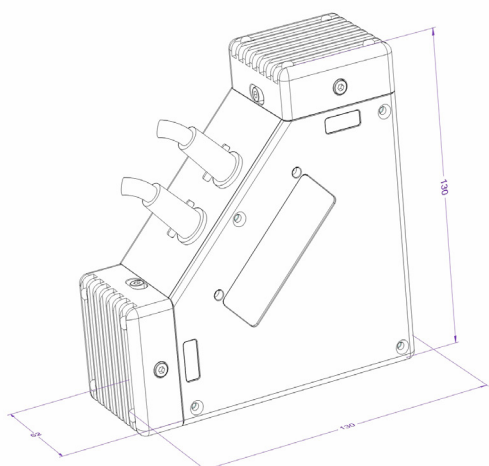

APPLICATIONS

- Fast calcium imaging and photometry
- FuraLED / GFP coupling combination
- Fura-2 (340nm / 380nm) or Fura-8 (365nm / 405nm)

KEY BENEFITS

- Dedicated Fura modular illuminator
- Sub-millisecond, vibration free digital and analogue switching
- Compatible with existing OptoLED controllers and Cairn microscope couplings
- OptoLED controller provides dual digital inputs for combined software and direct camera connection to reduce photobleaching
- Couple to Cairn Multistream for calcium imaging at maximum camera frame rates
- Full range of microscope / macroscope couplings available

ILLUMINATION SYSTEMS

DATASHEET

INTENSITY, STABILITY AND FLEXIBILITY



MultiLine LaserBank

Modular and versatile laser launch system allows for use of up to six solid-state lasers from multiple manufacturers. Ideal for TIRF, spinning disk confocal, FRAP and optogenetic applications or any combination of these with multiple outlets via single or multi-mode fibres. Provides the convenience of a custom, turnkey system.



TriLine Laser Bank

The TriLine shares much of the modularity and flexibility of the MultiLine, but in a simpler and more compact package (up to 3 lasers). The design offers the flexibility to configure output ports via single or multi-mode fibres (or free space on request) for TIRF, FRAP, photolysis, spinning disk confocal, optogenetics and other research applications.



Aura Pro

Easy to use and affordable LED transmitted light source for phase imaging on a variety of inverted microscopes. Supports PhL, Ph1 and Ph2 phase objectives, or can be used as a standard brightfield transmitted light source. Triggerable, with an extended working distance ideal for use with micromanipulators.



OptoLED

The OptoLED is our flagship system for LED illumination. Dual channel LED controller with ultra-high stability and "instantaneous" (sub-microsecond) vibration-free TTL switching and analogue intensity modulation.



MonoLED

Compact and affordable single LED white light illuminator for brightfield, phase contrast or DIC imaging, available with a wide range of microscope adapters. Convenient for any application requiring a simple LED illuminator.



OptoScan

The only monochromator that provides submillisecond control of both centre wavelength and bandwidth. Provides unmatched versatility for fluorescence measurements, photometry and optical scanning. A lab workhorse!



MultiPort Illumination Couplings

Easily and efficiently couples multiple light sources (light guide, laser or LED) into a single epi-illumination path. Well suited for optogenetics, photolysis and photoactivation. Can include independent field stops or pinholes.



OptoTIRF V2

The OptoTIRF is a compact and powerful, yet inexpensive, motorised TIRF illuminator designed to fit onto any research-grade inverted microscope. It gives the researcher intuitive and dynamic access to the entire back aperture of the objective with joystick or software control and simple storage and recall of preset positions

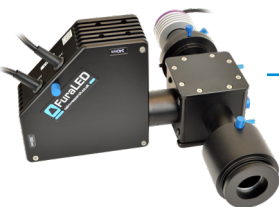

FuraLED

Compact and optimised LED illuminator for 340nm / 380nm ratiometric Fura-2 fluorescence imaging with integrated filters. Fast switching with photodiode feedback stability when used in conjunction with our OptoLED dual channel LED controller. Couples to a variety of upright / inverted microscopes or macroscopes.